

Max Frame	DP Rating	Impact
61 3/8" X 60"	+50/-65	YES

**Installed Fastener Schedule:**

1. Seal flange/frame to substrate.
2. Use #8 PH or greater fasteners through nail fin with sufficient length to penetrate a minimum of 1 1/2" into the wood framing. For 2X wood frame substrate (min. S.G. = 0.42).
3. Host structure (wood buck, stud framing and opening) to be designed and anchored to properly transfer all loads to the structure. The host structure is the responsibility of the architect or engineer of record for the project of installation.

**General Notes:**

1. The product shown herein is designed, tested and manufactured to comply with the wind load criteria of the adopted International Building Code (IBC), the International Residential Code (IRC), the Florida Building Code (FBC) and the industry standard requirement for the stated conditions.
2. Buck, framing and masonry by others and its responsibility of architect or engineer of record.
3. All glazing shall conform to ASTM E1300.
4. At minimum, glazing shall be 5.0mm annealed - 10.3mm airspace - 2.5mm annealed - 2.3mm PVB Interlayer by DuPont - 2.5mm annealed insulating glass.

This schedule addresses only the fasteners required to anchor the window to achieve the rated design pressure up to the size limitations noted. It is not intended as a guide to the installation process and does not address the sealing consideration that may arise in different wall conditions. For the complete installation procedure, see the instructions packaged with the door or go to [www.jeld-wen.com](http://www.jeld-wen.com).

**DISCLAIMER:**

This drawing and its contents are confidential and are not to be reproduced or copied in whole or in part or used or disclosed to others except as authorized by JELD-WEN Inc.

PROJECT ENGINEER: ---	DATE: 10/12/2015		3737 Lakeport Blvd Klamath Falls, OR, 97601 Phone: (800) 535-3936
DRAWN BY: D. VEZO	SCALE: NTS		
CHECKED BY: L. Moladore	TITLE: Siteline Clad Double Hung Picture Impact Window		
APPROVED BY: D. Stokes			
PART/PROJECT No.: D012102	PLANT NAME AND LOCATION: ---	CAD DWG. No.:	REV:
IDENTIFIER No. SJW2015-142			SHEET

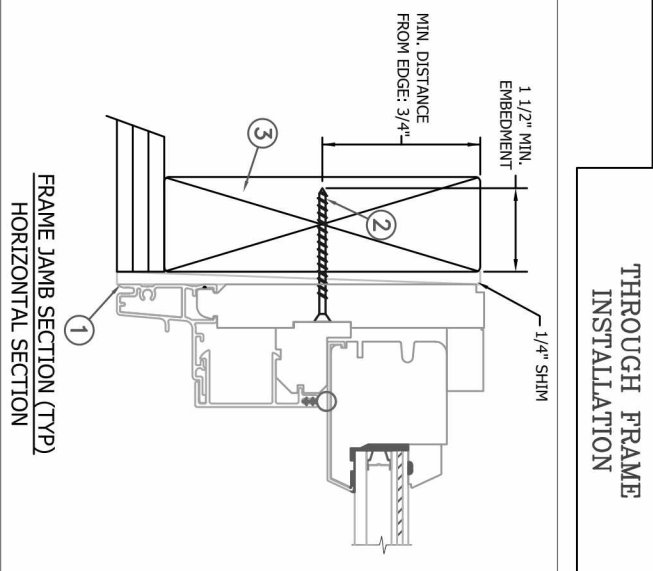
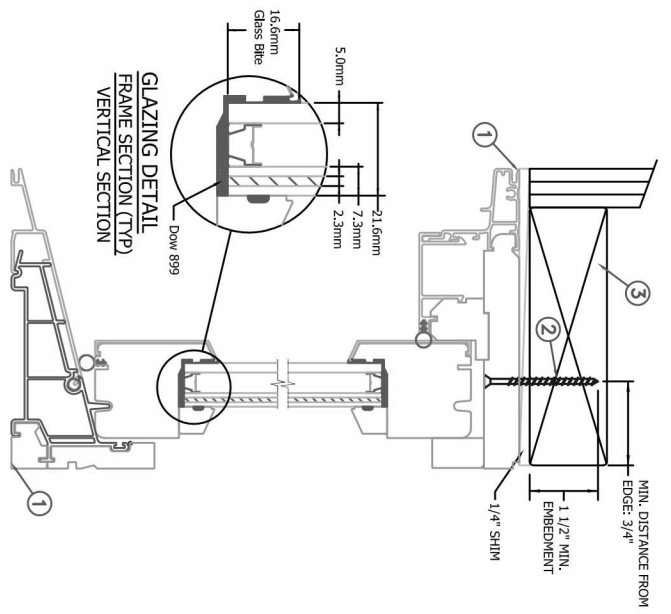
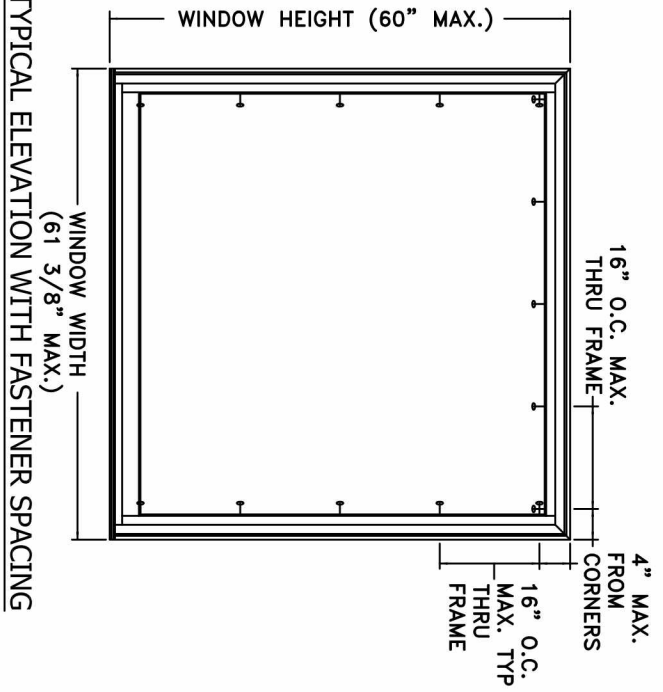

Max Frame	DP Rating	Impact
61 3/8" X 60"	+50/-65	YES

**Installed Fastener Schedule:**

1. Seal flange/frame to substrate.
2. Use #8 PH or greater fasteners through frame with sufficient length to penetrate a minimum of 1 1/2" into the wood framing. For 2X wood frame substrate (min. S.G. = 0.42).
3. Host structure (wood buck, stud framing and opening) to be designed and anchored to properly transfer all loads to the structure. The host structure is the responsibility of the architect or engineer of record for the project of installation.

**General Notes:**

1. The product shown herein is designed, tested and manufactured to comply with the wind load criteria of the adopted International Building Code (IBC), the International Residential Code (IRC), the Florida Building Code (FBC) and the industry standard requirement for the stated conditions.
2. Buck, framing and masonry by others and its responsibility of architect or engineer of record.
3. All glazing shall conform to ASTM E1300.
4. At minimum, glazing shall be 5.0mm annealed - 10.3mm airspace - 2.5mm annealed - 2.3mm PVB Interlayer by DuPont - 2.5mm annealed insulating glass.

This schedule addresses only the fasteners required to anchor the window to achieve the rated design pressure up to the size limitations noted. It is not intended as a guide to the installation process and does not address the sealing consideration that may arise in different wall conditions. For the complete installation procedure, see the instructions packaged with the door or go to [www.jeld-wen.com](http://www.jeld-wen.com).

**DISCLAIMER:**

This drawing and its contents are confidential and are not to be reproduced or copied in whole or in part or used or disclosed to others except as authorized by JELD-WEN Inc.

PROJECT ENGINEER: ---	DATE: 10/12/2015	<b>JELD-WEN</b>	3737 Lakeport Blvd Klamath Falls, OR, 97601 Phone: (800) 535-3936
DRAWN BY: D. VEZO	SCALE: NTS		
CHECKED BY: L. Moladore	TITLE: Siteline Clad Double Hung Picture Impact Window		
APPROVED BY: D. Stokes			
PART/PROJECT No.: D012102			
IDENTIFIER No. SJW2015-142	PLANT NAME AND LOCATION:	CAD DWG. No.:	REV:
			SHEET

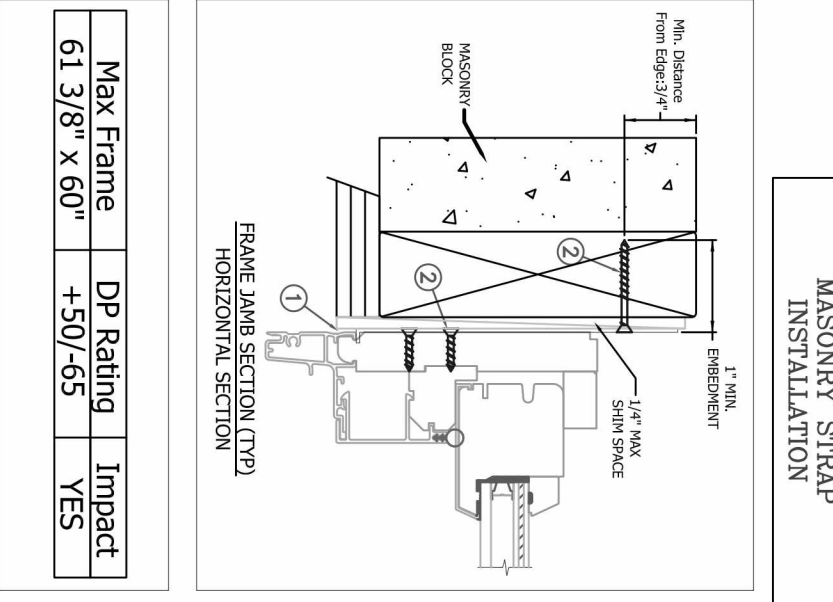
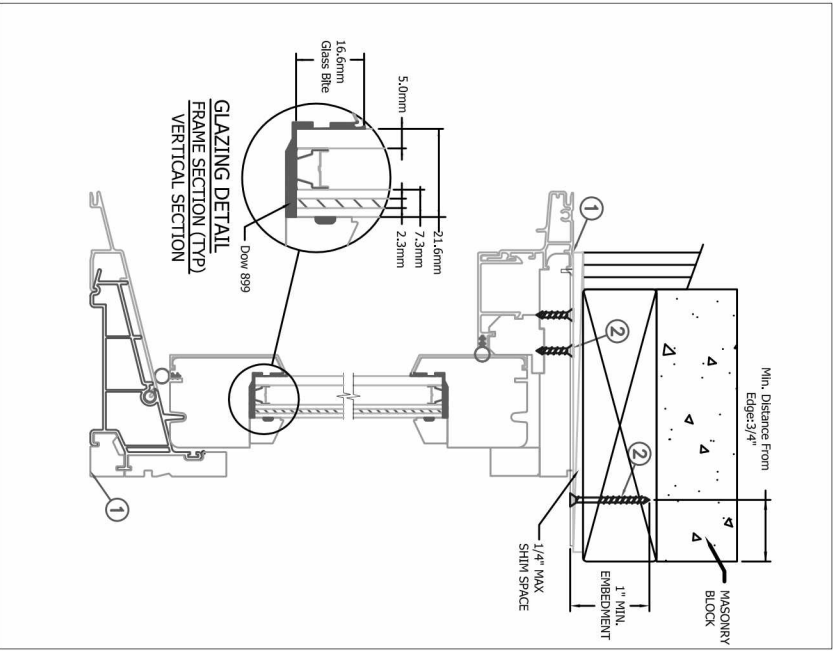
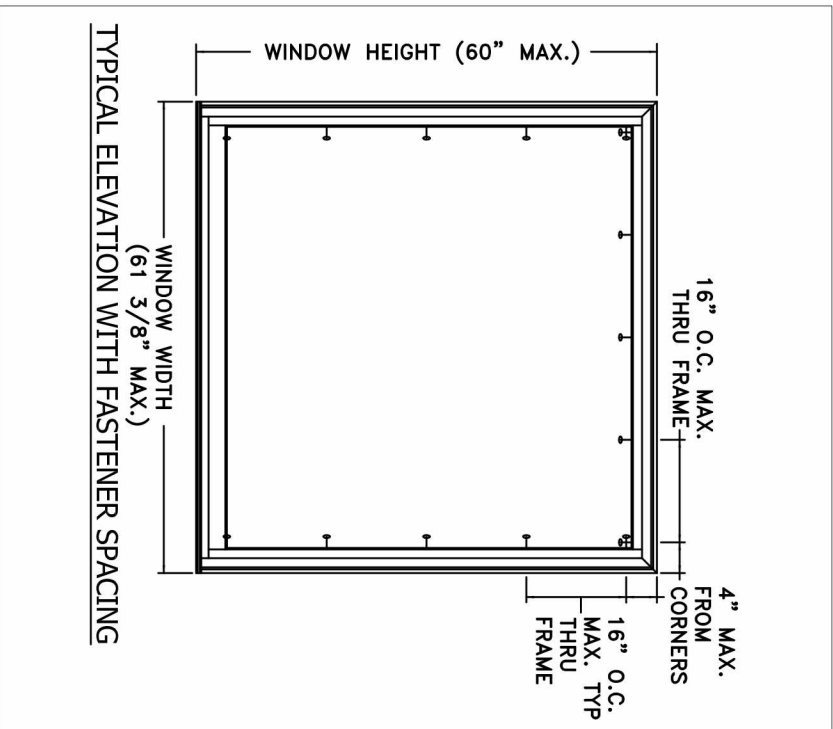

Max Frame	DP Rating	Impact
61 3/8" x 60"	+50/-65	YES

**Installed Fastener Schedule:**

1. Seal flange/frame to substrate.
2. Install masonry straps to wood frame using #8 corrosion resistant fasteners no more than 4" from each corner and 16" o.c. along the jambs and head. Bend straps around buck and secure with #8 fastener thru masonry strap into buck. Fasteners must be long enough to penetrate at least 1" into framing members.
3. Host structure (wood buck, stud framing and opening) to be designed and anchored to properly transfer all loads to the structure. The host structure is the responsibility of the architect or engineer of record for the project of installation.

**General Notes:**

1. The product shown herein is designed, tested and manufactured to comply with the wind load criteria of the adopted International Building Code (IBC), the International Residential Code (IRC), the Florida Building Code (FBC) and the industry standard requirement for the stated conditions.
2. Buck, framing and masonry by others and its responsibility of architect or engineer of record.
3. All glazing shall conform to ASTM E1300.
4. At minimum, glazing shall be 5.0mm annealed - 10.3mm airspace - 2.5mm annealed - 2.3mm PVB Interlayer by DuPont - 2.5mm annealed insulating glass.

This schedule addresses only the fasteners required to anchor the window to achieve the rated design pressure up to the size limitations noted. It is not intended as a guide to the installation process and does not address the sealing consideration that may arise in different wall conditions. For the complete installation procedure, see the instructions packaged with the door or go to [www.jeld-wen.com](http://www.jeld-wen.com).

**DISCLAIMER:**

This drawing and its contents are confidential and are not to be reproduced or copied in whole or in part or used or disclosed to others except as authorized by JELD-WEN Inc.

PROJECT ENGINEER: ---	DATE: 10/12/2015	PLANT NAME AND LOCATION: ---	
DRAWN BY: D. VEZO	SCALE: NTS	CAD DWG. No.:	REV:
CHECKED BY: L. Moladore	TITLE: Siteline Clad Double Hung Picture Impact Window	REV:	SHEET
APPROVED BY: D. Stokes			
PART/PROJECT No.:			
D012102			
IDENTIFIER No.:			
SWJ2015-142			



3737 Lakeport Blvd  
Klamath Falls, OR, 97601  
Phone: (800) 535-3936